

LFP24200C

Lithium Iron Phosphate Battery



FEATURES & BENEFITS

High Cycle Life

3500 Cycles @ 80%DoD SOC for Effectively Lower Total of Ownership Cost.

Longer Service Life

Low Maintenance Batteries With Stable Chemistry.

Built in Circuit Protection

Battery Management System (BMS) is Incorporated Against Abuse.

Better Storage

Up to 6 Months Thanks to Its Extremely Low Self Discharge (LSD) Rate And No Risk of Sulphation.

Quickly Recharge

Save Time And Increase Productivity With Less Down Time Thanks to Superior Charge/Discharge Efficiency.

Extreme Heat Tolerance

Suitable for Use in a Wider Range of Applications Where Ambient Temperature is Unusually High: Up to +°60C.

Light Weight

Lithium Batteries Provide More Wh/Kg While Also Being Up to 3/ 1 the Weight of its SLA Equivalent.

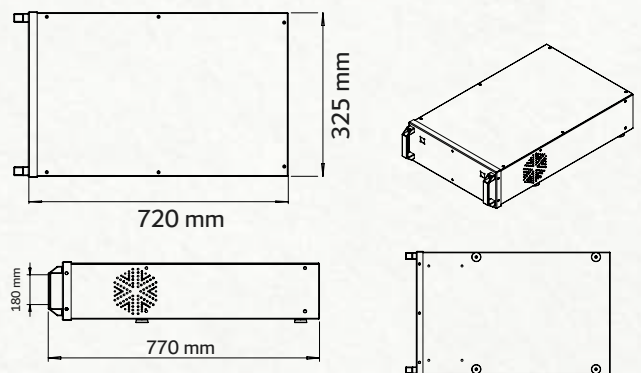

APPLICATIONS

Lithium Iron Phosphate Can Be Used in Most Applications That Use Lead Acid, GEL or AGM Type Batteries. Suitable Applications Include:

- Solar Storage.
- Switching Applications And More.
- Base Transceiver Station.
- Communication Equipments.
- Central Office.
- Telecommunication Systems.
- Electronic Cash Registers.
- Microprocessor Based Office Machine.
- UPS.

SYSTEM DIAGRAM

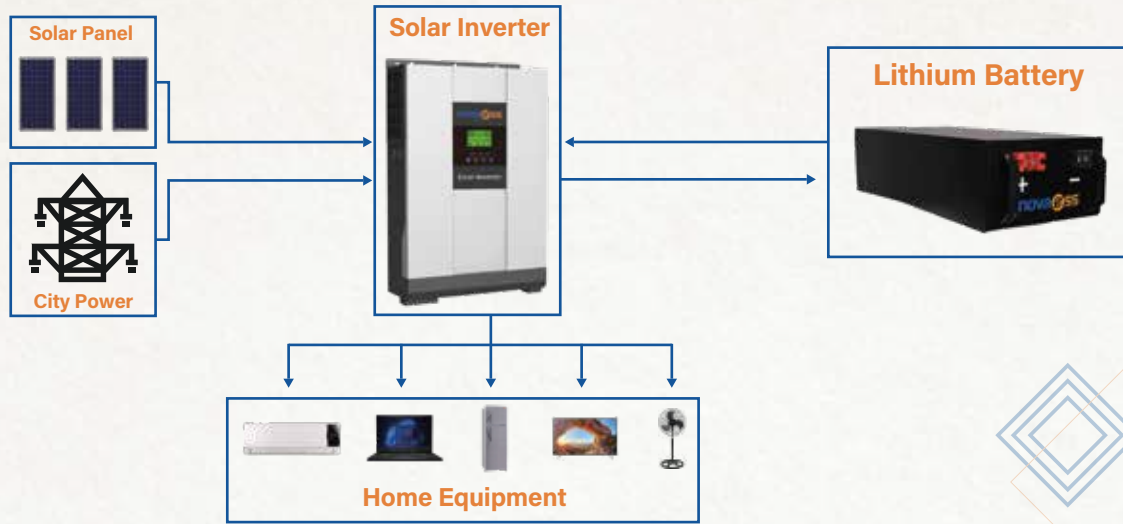

ELECTRICAL PERFORMANCE		MECHANICAL PERFORMANCE		
Nominal Capacity	200Ah	Dimension (LxWxH)	720 x 325 x 180 mm	
Capacity@50A	240 min	Approx. Weight	45 kg	
Energy	5.12 KWh	Terminal Type	PG38 Screw copper terminal	
Communication	Bluetooth, RS485 & CAN(Optional)	Terminal Torque	9 ~11N-m	
Resistance	≤45mΩ@50%SOC	Case Material	SPPC	
Efficiency	>96%	Enclosure Protection	IP55	
CHARGE PERFORMANCE		TEMPERATURE PERFORMANCE		
Module Parallel	Upto3packs	Discharge Temperature	-20 ~33°C	
Recommended Charge Current	80 A	Charge Temperature	0 ~43°C	
Maximum Charge Current	120 A	Storage Temperature	-3 ~33°C	
Recommended Charge Voltage	28.5 V	BMS High Temperature Cut-Off	63°C	
BMS Charge Cut-Off Voltage	<29.2 V(3.65V/Cell)	Reconnect Temperature	33 °C	
Reconnect Voltage	>28.8 V(3.6V/Cell)	HEATING FOIL PERFORMANCE		
Balancing Voltage	<28.8 V(3.6V/Cell)	Heating Temperature Range	-5 to 45 °C	
Maximum Batteries in Series	8 if we use RS485 and CAN option	BMS Heating Foil Cut-Off	70°C	
DISCHARGE PERFORMANCE		COMPLIANCE		
Maximum Continuous Discharge Current	150 A/100 A	Certifications	UL1642 & IEC62133 (cells)	
Peak Discharge Current	300 A/200 A	Shipping Classification	UN3480,CLASS9	
BMS Discharge Cut-Off Current	310 A/210 A	Battery Dimensions		
Balancing Open Voltage	27.6 V(3.45V/Cell)	Length	Width	Height
Recommended Low Voltage Disconnect	23.5 V(2.75V/Cell)	720 mm	325 mm	180 mm
BMS Discharge Cut-Off Voltage	>20 V(2s)(2.0V/Cell)			
Reconnect Voltage	>21 V(2.5V/Cell)			
Short Circuit Protection	250~500µs			

CAUTIONS

- Do NOT Short Circuit, Reverse Polarity, Crush or Disassemble.
 - Do NOT Heat or Incinerate.
 - Do NOT Immerse in Any Liquid.
 - Store At 30~50% SOC. Recharging Every 3 Months is Recommended.
- The Storage Area Should be Clean, Cool, Dry and Ventilated.

Performance May Vary Depending on Application. All Specifications are Subject to Change Without Prior Notice to The User. This Data is For Evaluation Purposes Only. No Guarantee is Intended or Implied By This Data. For Clarification And Updated Information, Please Contact Us.

nova@ess
NOVA Energy Storage Systems

f in nova-ess

+971581446678 info@nova-ess.com